

Micro cutting tools

HPTec MICRO-Line

do grafitu

for graphite

RDK 210



Frez węglkowy 2-piórowy
z końcówką kulistą
(pokrycie diamentowe) do grafitu

2-Flute router with ball nose
(diamond coated) for graphite

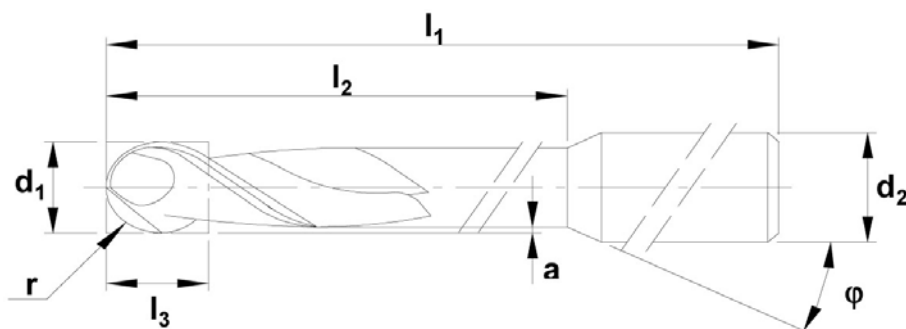

TYP: RDK 210

NORMA: HPTec Standard

KĄT POCHYLENIA SPIRALI: $\lambda = 40^\circ$

UCHWYT WALCOWY: DIN 6535 HA

POKRYCIE: Diamentowe

MATERIAŁ SKRAWAJĄCY: Węglik spiekany

TYPE: RDK 210

STANDARD: HPTec Standard

HELIX ANGLE: $\lambda = 40^\circ$

STRAIGHT SHANK: DIN 6535 HA

COATING: Diamond

CUTTING MATERIAL: Solid carbide

d_1 [mm]	r [mm]	l_3 [mm]	l_1 [mm]	l_2 [mm]	d_2 [mm]	z	a [mm]	ϕ [°]	Nr katalogowy
0,30	0,15	1,50	60,00	2,50	6,00	2	0,010	7	511300
0,50	0,25	1,50	60,00	3,50	6,00	2	0,010	7	511301
0,50	0,25	1,50	60,00	7,00	6,00	2	0,010	7	511305
1,00	0,50	3,00	60,00	5,00	6,00	2	0,025	7	511302
1,00	0,50	3,00	60,00	10,00	6,00	2	0,025	7	511306
1,50	0,75	3,00	60,00	10,00	6,00	2	0,025	10	511307
2,00	1,00	3,00	40,00	12,00	3,00	2	0,100	15	511334
3,00	1,50	4,00	60,00	12,00	6,00	2	0,100	15	511335